

The Open University of Sri Lanka
Faculty of Engineering Technology
Department of Textile and Apparel Technology



Study Programme	: Bachelor of Technology Honours in Engineering/ Bachelor of Industrial Studies Honours
Name of the Examination	: Final Examination
Course Code and Title	:TAX4361 Knitting Technology
Academic Year	: 2019/2020
Date	: 06 th October 2020
Time	: 09:30-12:30 hrs
Duration	: 3 hours

General Instructions

1. Read all instructions carefully before answering the questions.
2. This question paper consists of Eight (8) questions in Six (6) pages.
3. Write down your Index Number in all the pages of the answer script.
4. **Answer compulsory question one (Q1) and additional five (05) questions.**
5. Question one (Q1) is compulsory and carries twenty five (25) marks.
6. Question two (Q2) to eight (Q8) carry fifteen (15) marks each.
7. Answer for each question should commence on a new page. If a question has many parts, all the parts should be answered in the chronological order under the same question.
8. Write down the answered question numbers in the space given in the answer book.
9. Answers should be in clear hand writing.
10. Do not use red colour pen.

Compulsory question

(Q1)

- a. Briefly explain the reasons for the fast growth of the knitting technology compared to weaving industry. (03 Marks)
- b. State three (03) objectives of lubrication of yarns for weft knitting. (03 Marks)
- c. Give an outline classification of weft knitting machines. (03 Marks)
- d. Briefly explain the following terms. (02 Marks)
 - i. Rib gating
 - ii. Interlock gating
- e. List three (03) different types of circular knitting machines that are categorized according to the needle bed arrangement. (03 Marks)
- f. Briefly explain following relaxation processes of knitted fabrics. (02 Marks)
 - i. Dry relaxation
 - ii. Wet relaxation
- g. State the functions of sinkers in the knitting machines listed below.
 - i. Tricot warp knitting machine
 - ii. Raschel warp knitting machine (02 Marks)
- h. Write the chain notation and lapping diagram of the following warp knitted structure. (02 Marks)

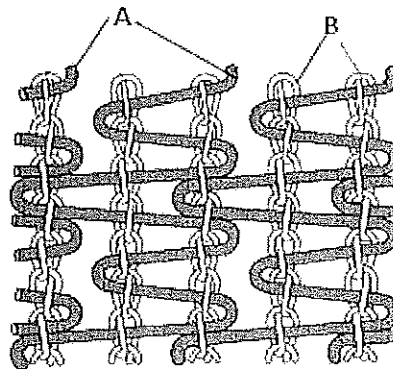

- i. Compare operational mechanism of bi-partite compound needle and bearded needle during knitting. (02 Marks)
- j. Briefly explain what you understand by "Fall plate" and intended functions during warp knitting. (03 Marks)

Answer any five (05) questions from the following seven (07) questions.

(Q2) (a) Discuss the effect of yarn twist on the properties of knitted fabrics. (03 Marks)

(b) Briefly explain how the following yarn properties and characteristics effect on process of knitting or quality of the knitted fabrics. (06 Marks)

- i. Flexural rigidity
- ii. Tenacity
- iii. Yarn hairiness

(c) Compare "Negative yarn feeding" and "Positive yarn feeding" used in weft Knitting with special reference to their advantages and disadvantages. (06 Marks)

(Q3) (a) Compare weaving and weft knitting considering at least five features. (05 Marks)

(b) Compare 2x2 rib and interlock knitted fabrics considering the following.

- a. Appearance of technical face of the fabric
 - b. Appearance of technical back of the fabric
 - c. Stretchability in wale direction
 - d. Stretchability in course direction
 - e. Ability to unravel a yarn from the structure
 - f. Tendency to curl
- (06 Marks)

(c) Draw the yarn path and the point paper notations of the loop diagram given below. (04 Marks)

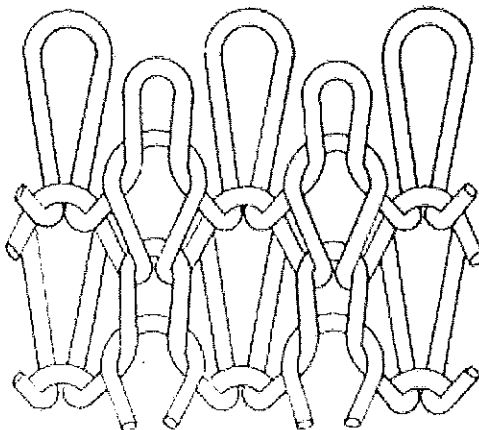

- (Q4) (a) Compare circular weft-knitting and V-bed flat knitting considering machine, process, and structures. (06 Marks)
- (b) Compare the actions of loop formation by bearded and latch needles. (05 Marks)
- (c) Discuss the different types of hosiery machines and their products. (04 Marks)
- (Q5) (a) Draw needles and cam arrangement to knit one repeat of "Taxi Pique" structure on circular interlock knitting machine. Label the individual cams, arrangement of needles in needle beds, the direction of movement of knitting needles and cams to produce each course. (10 Marks)



- (b) With the use of suitable diagrams briefly explain the basic principle of plating technique. (05 Marks)

- (Q6) A fully fashioned garment component with the following specification is required to be knitted.

Courses per inch = 40

Wales per inch = 25

The requirements are given in the diagram below.

Do the calculations and write the knitting statements. Clearly show all the calculation steps. (15 Marks)

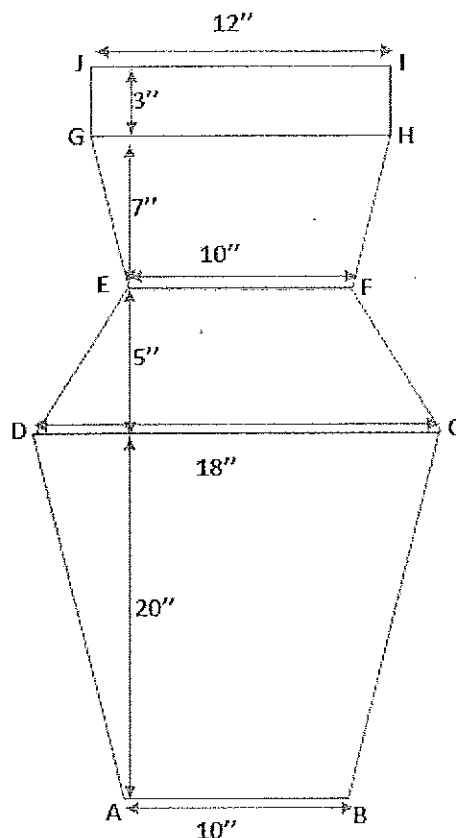

- (Q7) (a) A wet relaxed, plain knitted worsted fabric has 64 stitches / cm² and the fabric made of 40 Tex yarns. If the relaxation constants, K_s , K_c and K_w of wet-relaxed fabrics are 2160, 53 and 41 respectively in metric units, calculate the following.
- The stitch length (02 Marks)
 - The number of courses per centimeter (02 Marks)
 - The number of wales per centimeter (02 Marks)
 - The weight of the fabric (03 Marks)

(b) Calculate the front bar stitch length and back bar stitch length of a warp knitted structure, if front bar and back bar run-in values are 153 cm and 104 cm respectively. (06 Marks)

- (Q8)** (a) Compare the differences and similarities between warp knitting and weft knitting related to knitting needles, yarn feed mechanisms, loop forming principle and types of stitches and/or loops. (06 Marks)
- (b) Compare the two different pattern mechanisms to push the guide bars in warp knitting machines highlighting their advantages and disadvantages. (05 Marks)

(c) Draw the lapping diagrams for the following warp knitted fabric structure.

Front bar chain notation: 1-0/1-2/2-3/3-4/2-1/2-3

Back bar chain notation : 2-3/1-0/1-2/1-0/0-1/1-2 (04 Marks)