

The Open University of Sri Lanka  
Faculty of Engineering Technology  
Department of Electrical and Computer  
Engineering



Study Programme	: Bachelor of Technology Honours in Engineering
Name of the Examination	: Final Examination
<b>Course Code and Title</b>	<b>: EEX5531 Network theory</b>
Academic Year	: 2020/21
Date	: 06 <sup>th</sup> February 2022
Time	: 1400-1700 hrs
Duration	: <b>3 hours</b>

### General Instructions

1. Read all instructions carefully before answering the questions.
  2. This question paper consists of **Seven (7)** questions in **Five (5)** pages.
  3. Answer any **Five (5)** questions only. All questions carry equal marks.
  4. Answer for each question should commence from a new page.
  5. No charts/ codes are provided.
  6. This is a Closed Book Test (CBT).
  7. Answers should be in clear handwriting.
  8. Do not use Red colour pen.
-

### Question 01

Figure 1 shows a LTIC system which is having an input  $u(t)$  and two outputs  $y_1(t)$  and  $y_2(t)$ .

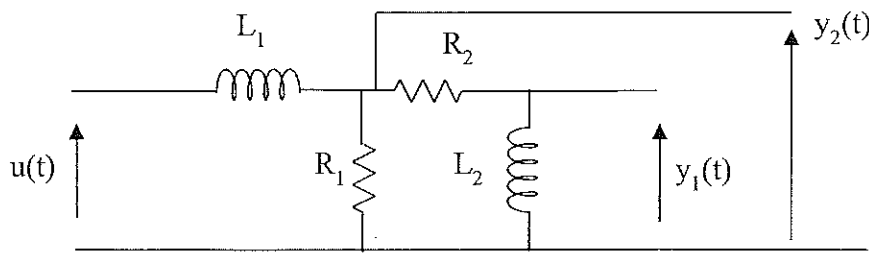

Figure 1

- Write state equations for the system given in Figure 1, by selecting proper state variables. (05 marks)
- Represent the state equations in standard matrix form and clearly indicate the matrices A, B, C, and D as per the standard notation. (05 marks)
- Derive an expression for the zero-input response of the given system in terms of component values. Assume that the initial currents of  $L_1$  and  $L_2$  are similar and equal to 0.1 A. Evaluation of state transition matrix is not required (05 marks)
- Develop an algorithm to find the zero-input response of the system and interpret it using a flow chart. Period of response is T (0 to T seconds). Calculation step size should be  $T/100$ . (05 marks)

### Question 02

Consider the circuit shown in Figure 2.

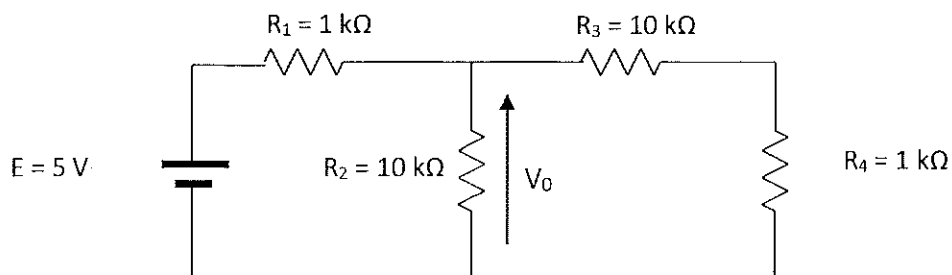

Figure 2

- Draw the adjoint network for the circuit shown in figure 2. Use standard notation to mark currents and voltages. (05 marks)
- Using the extended Tellegen's theorem, find the sensitivity of  $(V_0)$  – the voltage across  $R_2$  – for changes in each element  $R_1$ ,  $R_2$ ,  $R_3$  and  $R_4$  separately. Assume a change in only one component at a time. (10 marks)
- If  $R_2$  has a tolerance of 10%, calculate the range of variation of  $V_0$ . Assume all other components have their designated values. (05 marks)

**Question 03**

State equations of a LTI system are given below.

$$[\dot{x}(t)] = [A]x(t) + Bu(t)$$

$$y(t) = [C]x(t) + Du(t)$$

- i. Using Laplace transform, convert the state space equations into s-domain. (02 marks)
- ii. Obtain an expression for the transfer function of the system in matrix form. (02 marks)
- iii. Using the matrices given below, obtain the transfer function of the system. (08 marks)

$$A = \begin{bmatrix} -400 & 200 \\ 1000 & -10000 \end{bmatrix}, B = \begin{bmatrix} 0 \\ 11000 \end{bmatrix}, C = \begin{bmatrix} 1 & 0 \\ 0 & 1 \end{bmatrix}, D = [0]$$

- iv. Using the transfer function obtained in (iii), calculate the magnitude of the given system at following frequencies. You may consider the input to the system is always kept at unity (1 unit) for all the frequencies. (03 marks)
  - a. 100 rads<sup>-1</sup>
  - b. 10000 rads<sup>-1</sup>
- v. Develop an algorithm to find the frequency response (magnitude only) of the system and interpret it using a flowchart. (05 marks)

**Question 04**

A first order RL circuit has series connected 20 mH inductor and a 1.2 kΩ resistor. The circuit is energized at t = 0 s using a 15 V DC source. Initially, energy stored in the inductor is zero.

- i. Using Backward Euler method of integration, formulate the companion model of energy storing element for nodal analysis. (Time step = 10 μs) (05 marks)
- ii. Draw the complete equivalent circuit using the companion model. (02 marks)
- iii. Calculate the current through the circuit at 10 μs, 20 μs and 50 μs. (08 marks)
- iv. Develop an algorithm to generate the transient response of the current through the circuit and interpret it using a flow chart. (05 marks)

### Question 05

Consider the MOSFET amplifier circuit shown in figure 3. The high frequency model of the MOSFET is shown in figure 4. Assume that the circuit is operating at steady-state.

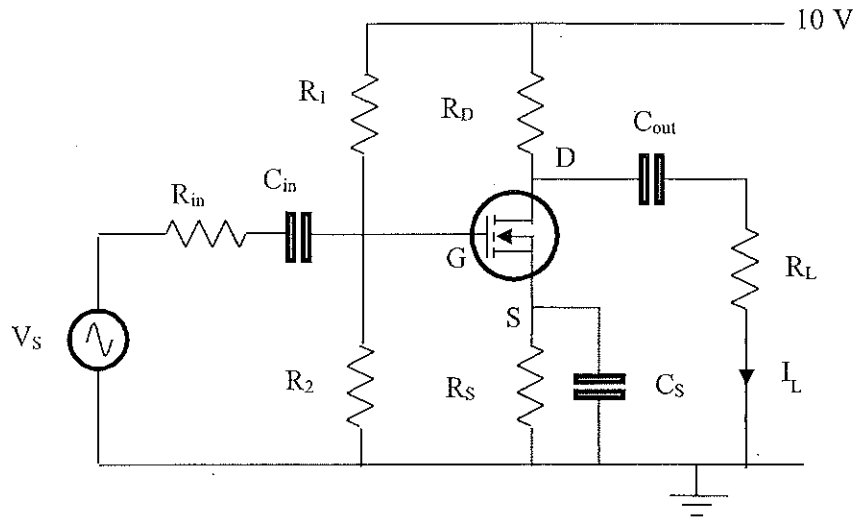

Figure 3

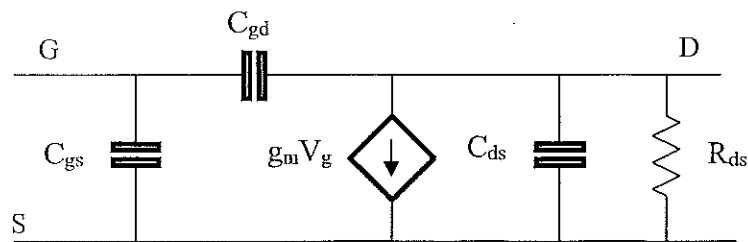

Figure 4

- i. Draw the high frequency equivalent circuit of the MOSFET circuit shown in figure 3, using the high frequency model of the MOSFET shown in figure 4. Clearly indicate the assumptions you made. (04 marks)
- ii. Set the stamps for each element using modified nodal analysis. (06 marks)
- iii. Write the matrix equation of the circuit to find the voltages at all nodes and output current  $I_L$  using the stamps you have set in (ii). (10 marks)

### Question 06

Figure 5 shows an electric circuit consisting passive elements and two AC voltage sources.

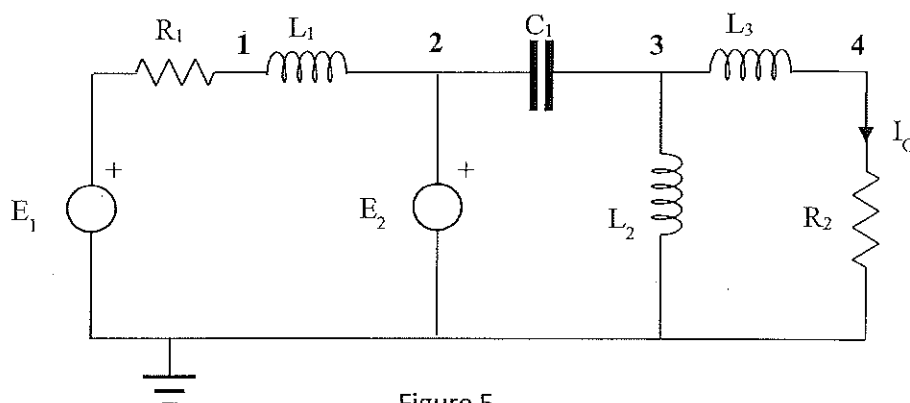

Figure 5

- i. Set the stamps for each element of the circuit using modified nodal analysis. (10 marks)
- ii. Write the matrix equation to find the voltages at points 1, 2, 3, 4 and output current  $I_0$  using the stamps you have obtained in (i). Solving the equation is not required. (10 marks)

### Question 07

a) Consider the circuit shown in figure 6.

- i. Show how the circuit shown in figure 6 is solved using graphical method. You may draw graphs and qualitatively indicate necessary details. (05 marks)

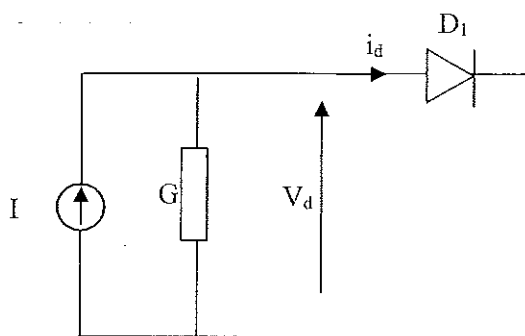

Figure 6

- ii. Develop the companion model of the diode. (05 marks)
- b) A circuit with two diodes  $D_1$  and  $D_2$  is shown in figure 7. Characteristic equation of any of the diodes is given by  $i_d = I_s(e^{\lambda V_d} - 1)$ . Assume  $I_s = 1 \times 10^{-13}$  A and  $\lambda = 1/0.026$  V $^{-1}$ .

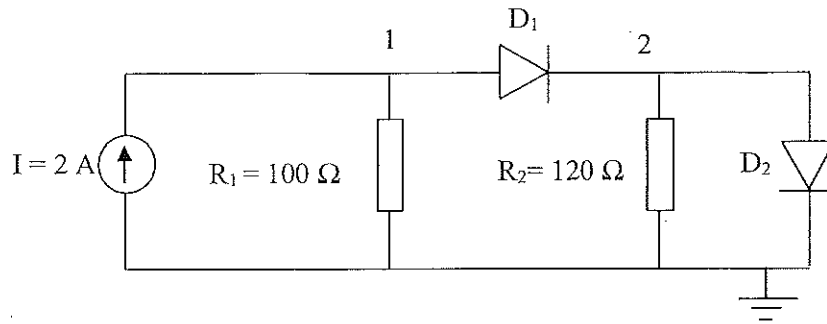

Figure 7

- i. Formulate the matrix equation using non-linear analysis for modified nodal analysis. You may use the companion model of the diode you have developed in (a) ii of this question. *(03 marks)*
- ii. With the help of the matrix equation obtained in part i, write the steps of the algorithm to calculate the nodal voltages of the circuit. *(04 marks)*
- iii. Draw a flow chart to represent the algorithm you have used in (ii). *(03 marks)*