



Study Program : Bachelor of Science Honours in Engineering/
Bachelor of Technology Honours in Engineering/
Bachelor of Industrial Studies Honours

Name of the Examination : Final Examination

Course Code and Title : TAX4361 Knitting Technology

Academic Year : 2022/2023

Date : 18th of February 2024

Time : 09:30 – 12:30 hrs

General Instructions:

1. Read all instructions carefully before answering the questions.
2. This is a Closed Book Test (CBT).
3. This question paper consists of **Eight (08)** questions in **Six (06)** Pages.
4. Write down your Index Number on all the pages of the answer script.
5. **Answer Compulsory Question One (Q1) and additional Five (05) questions.**
6. **Question One (Q1)** is compulsory and carries **Twenty-Five (25)** marks.
7. **Question Two (Q2) to Eight (Q8)** carry **Fifteen (15)** marks.
8. The answer for each question should commence from a new page. If a question has many parts, all the parts should be answered in chronological order under the same question.
9. Write down the answered question numbers in the space given in the answer book.
10. Answers should be in clear handwriting.
11. Do not use a red color pen.

(Compulsory Question)

(Q 01)

- a) State Three (03) reasons for the enormous growth of the Knitting Industry in comparison to Weaving. (03 Marks)
- b) State the functions of the following components of circular knitting machines. (02 Marks)
- i) Feeders
 - ii) Guides
- c) List two (02) types of latch needles and briefly explain their applications. (03 Marks)
- d) Distinguish between synchronized timing and delayed timing in context of circular knitting machine. (02 Marks)
- e) The following structure is to be knitted on a circular knitting machine equipped with latch needles. Explain how you would arrange the cams and the needles on the machine. (04 Marks)

●	×
×	×
×	●
×	×

Figure Q1(g)

- f) Briefly explain how the following ornamentation is achieved in interlock fabrics. (02 Marks)
- i) Horizontal stripping
 - ii) Vertical Stripping
- g) Briefly explain the use of fall plates in warp knitting machines. (03 Marks)
- h) How do you differentiate the wet relaxed state and dry relaxed state of the knitted fabric? (02 Marks)
- i) Explain following defects and reasons for each defect formation in context of weft knitting. (04 marks)
- i) Barre:

ii) Ladder:

Answer any FIVE (05) questions from the following SEVEN (07) questions

(Q 02)

- a) List three (03) objectives of yarn lubrication in knitting. (03 Marks)
- b) State three (03) types of positive yarn feeding systems and explain one of them in detail. (06 Marks)
- c) "There should be a proper balance between needle hook size and the thickness of the yarn or filament used for knitting". Validate this Statement referring to the two (02) possible extremes of the outcome. (06 Marks)

(Q 03)

- a) Compare and contrast the five (05) loop formation stages of bearded and latch needles. (10 Marks)
- b)
- i) Write two (02) widely used individual needle selection mechanisms in weft knitting. (02 marks)
- ii) State three (03) factors which determine the selection of needle mechanism in the knitting machine. (03 marks)

(Q 04)

- a) List three (03) major functions performed by sinkers and explain how the sinkers are shaped to facilitate those functions. (06 Marks)
- b) Compare plain, rib and interlock knitted fabric considering the following; (05 marks)
- i) Appearance of technical face and back
- ii) Stretchability in wale direction
- iii) Stretchability in course direction
- iv) Ability to unravel a yarn from the structure
- v) Tendency to curl
- c) Using suitable digrams, define following terms; (04 marks)
- i) Rib gating
- ii) Interlock gating

(Q 05)

- a) Discuss needle arrangement and the knitting action of double cylinder purl knitting machine. (05 marks)
- b) Briefly explain how the laying yarns are introduced or fed during knitting process when one set of needles and two sets of needles are used. (04 marks)
- c) Describe briefly how "eyelet design" fabrics are manufactured on circular knitting machines. (06 Marks)

(Q 06)

- a) A fully fashioned garment component with the following specification is required to be knitted;

Courses per inch = 28

Wales per inch = 20

The requirements are given in the diagram below.

Do the calculation and write the knitting statements. Clearly show all the calculation steps (08 marks)

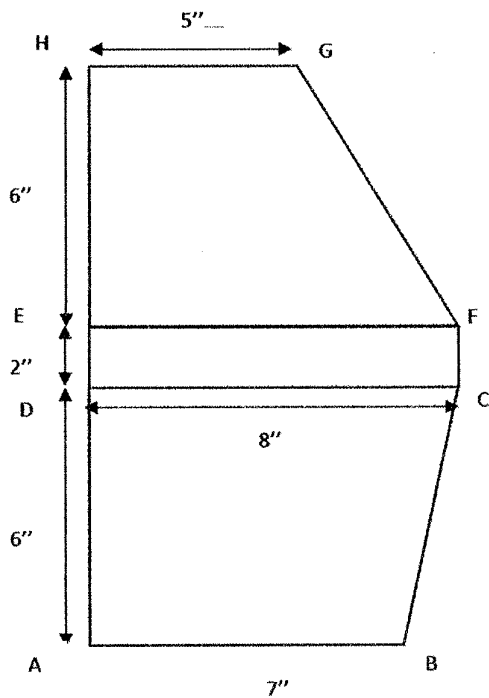

b) A wet relaxed, plain knitted worsted fabric has 480 stitches/cm². The yarn count of the fabric is 20 Tex yarn. If the relaxation constants, K_s , K_c and K_w of wet relaxed fabrics are 2160, 53 and 41 respectively in metric units, calculate the following.

- i) The stitch length (l) (02 marks)
- ii) The number of courses per centimeter (c) (01 marks)
- iii) The number of wales per centimeter (w) (01 marks)
- iv) The weight of the fabric GSM (03 marks)

(Q 07)

a) Proving examples, State the five main types of lapping variations used in the production of warp knitting structures. (05 marks)

b) Following are the lapping diagrams of two guide bars.

Guide Bar 01: 1-0/1-2/1-0/1-2/2-3/2-1/2-3/2-1//

Guide Bar 02: 2-3/2-1/2-3/2-1/1-0/1-2/1-0/1-2//

If this fabric is knitted using the following threading diagram, With the aid of the lapping diagram, comment on the appearance of the fabric produced. (06 Marks)

Guide Bar 01 : | . | . | . | . | . | .

Guide Bar 02 : | . | . | . | . | . | .

c) Give the chain notation of the front guide bar and the back guide bar for the warp structure lapping diagram given below, (04 marks)

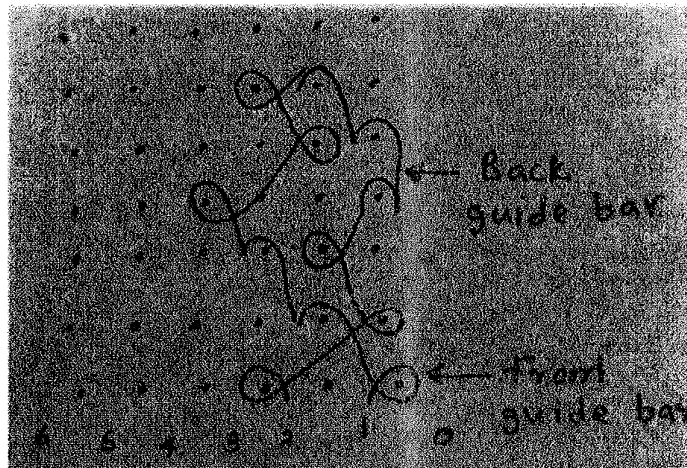

(Q 08)

- a) State five (05) benefits of using electronics in knitting machines. (05 Marks)
- b) Briefly explain the process of cup seaming machine used in fully-fashioned garment assembling. (04 marks)
- c) State three (03) main methods of producing spacer fabrics by circular knitting machines. (03 marks)
- d) Explain the classification of hosiery machines. (03 marks)