



Study Program	: Bachelor of Industrial Studies Honours
Name of the Examination	: Final Examination
Course Code and Title	: TAX4441 Knitted Garment Technology
Academic Year	: 2022/2023
Date	: 20 th February 2024
Time	: 09:30-12:30
Duration	: 3 hours

General Instructions

1. Read all instructions carefully before answering the questions.
2. This question paper consists of Eight (08) questions in Four (04) pages.
3. Write down your Index Number in all the pages of the answer script.
4. **Answer compulsory question one (Q1) and additional five (05) questions.**
5. Question one (Q1) is compulsory and carries twenty-five (25) marks.
6. Question two (Q2) to eight (Q8) carry fifteen (15) marks each.
7. Answer for each question should commence on a new page. If a question has many parts, all the parts should be answered in the chronological order under the same question.
8. Write down the answered question numbers in the space given in the answer book.
9. Answers should be in clear hand writing.
10. Do not use red colour pens.

Compulsory Question

(Q1)

- a. "Sinker" is considered as the second primary knitting element. Briefly explain three (03) main functions of a Sinker. (03 Marks)
- b. Name two(02) different types of warp knitting machines and briefly explain one(01) of them. (03 Marks)
- c. Draw one repeat of yarn path diagram of a 6 x 3 Rib fabric and give loop length formula for 6 x 3 Rib fabric. (03 Marks)
- d. State four (04) different relaxed states of knitted fabrics, which are used to determine the shrinkage. Briefly describe two (02) of the mentioned states. (04 Marks)
- e. Most of the computer software available for marker making are capable of performing lot of tasks. Mention four (04) of them. (04 Marks)
- f. In Cut stitch-shaped garment production, blanks are subjected to steam treatment before cutting and seaming. Give two (02) objectives of steaming the blanks. (02 Marks)
- g. In a plain knitted fabric, what is the lowest angle that can be practically created for shape generation by fully fashioning? Show relevant calculations. (the ratio of number of wales/unit length to that of the number of courses/unit length is 1:1.3) (02 Marks)
- h. Describe the structure and application of lock stitches used in knitted garment assembly. (04 Marks)

Answer any five (05) questions form the following seven (07) questions.

(Q2)

- (a) Compare "Fully-fashioned garment method" and "Integral garment method" of knitted garment production. State two (02) advantages of "Integral garment method". (08 Marks)
- (b) i) Explain the structure, lapping notation and chain notation of "Tricot" warp knit structure. (04 Marks)
- (c) ii) How does yarn consumption and the physical properties of the fabric vary between Tricot and 2x1 Lapping? (03 Marks)

(Q3)

- (a) State two (02) needle bed arrangements in knitting machines which used to produce double jersey fabric and describe how it differs from one another. Compare physical appearance of fabrics produced from mentioned arrangements. (09 Marks)
- (b) Draw yarn path diagrams of “Full Cardigan” and “Half Cardigan” fabric structures. Briefly explain how those fabrics are produced. (06 Marks)

(Q4)

- (a) A Finished-relaxed plain knitted fabric is made from 65Tex yarn and has an average stitch length of 5.2mm. Determine the stitch density, fractional cover and the cover factor of the fabric. The fiber density is 1.3. Relaxation constants k_s , k_c and k_w are 2360, 56 and 42.2 respectively in metric system. (09 Marks)
- (b) A weft knit fabric was produced with a stitch length of 2.3cm, 20 wales/cm and 35 courses/cm. If a fabric was produced with same specification except changing 26 wales/cm and 42 courses/cm, what would be the stitch length of the new fabric? (06 Marks)

(Q5)

- (a) Current trend in garment industry is to employ more and more computer-controlled automatic cutters for cutting fabrics. Discuss advantages and disadvantages of computer-controlled cutting. (08 Marks)
- (b) i) What are most important properties of a stitch and which property is essential for seaming of knitted garments? (03 Marks)
- ii) What are basic six (06) groups in British Standard classification of stitches? Name two (02) stitches especially suitable to knitted garments and state why are they suitable. (04 Marks)

(Q6)

- (a) i) State six (06) techniques used to shape the fabric in the production of integral garments. (03 Marks)
- ii) Name two (02) flat-bed knitting machines which use these techniques mentioned above in part (a) (i), and briefly describe features of those machines. (04 Marks)
- (b) Briefly describe knitted structures used in producing garment pieces for fully-fashioned knitted garments. Mention importance of each structure. (08 Marks)

(Q7)

- (a) What details are included in a “knitting statement”. (02 Marks)
- (b) A fully-fashioned garment component as shown below should be knitted with a specification of 20 courses per inch, and 16 wales per inch. Prepare a knitting statement for the knitting of the given fully-fashioned garment component. Clearly show all the calculations. (13 Marks)

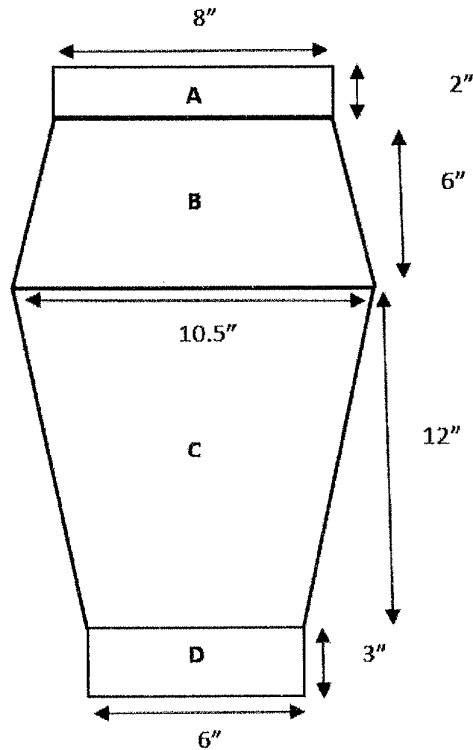

(Q8)

- (a) Define “seam” according to British Standards and Federal Standards. State the main difference between the given definitions. (06 Marks)
- (b) i) Illustrate and explain the main parts of a “Cup Seaming Machine” used in knitted garment assembly. (06 Marks)
- ii) Briefly describe the “gauge” of a linking machine used in assembly of knitted fabrics. (03 Marks)