



CEX4231 – Structural Analysis and Design II

FINAL EXAMINATION – 2011/2012

Time Allowed: Three (03) Hours

Date: 2012 - 03 - 09 (Friday)

Time: 0930 - 1230 hrs.

Answer Five (05) questions with at least Two (02) questions from each section.  
 Necessary extracts from BS 8110 will be provided separately.

**Section A - Structural Analysis**

Q1.

- a.) State the 1<sup>st</sup> Theorem of Moment Area Method.

[02 marks]

- b.) Using Moment Area Method, find the vertical deflection end B of the cantilever beam AB shown in Fig. 1(b). ( $EI = \text{constant}$ ).

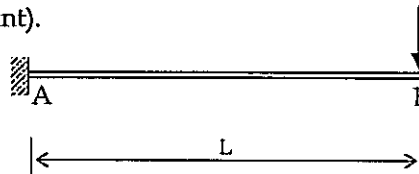

Fig. 1(b)

[04 marks]

- c.) Using the Theorem of Three Moments equations, analyse the beam ABC shown in Fig. 1(c) and draw the Bending Moment diagram.

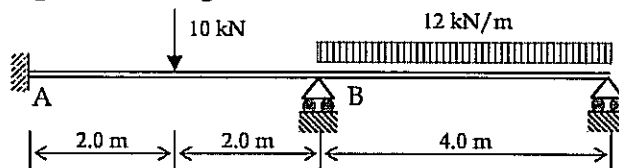

Fig. 1(c)

[14 marks]

Q2.

- a.) Using the Moment Area Method, find the slope at A for the simply supported beam shown in Fig. 2(a), ( $EI = \text{constant}$ ).

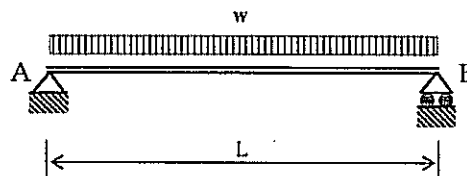

Fig. 2(a)

[04 marks]

- b.) Analyse the portal frame shown in Fig. 2(b) using Slope Deflection Equations and sketch the Bending Moment diagram ( $I$  values are indicated near the members).

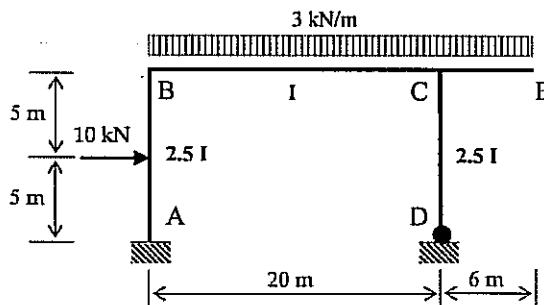

Fig. 2(b)

[16 marks]



Q3.

- a.) Beam AB in the Fig. 3(a) is fully fixed at B and freely supported at A. When a moment  $M_A$  is applied at A, calculate the magnitude of the moment induced at B ( $M_B$ ), ( $EI = \text{constant}$ ).

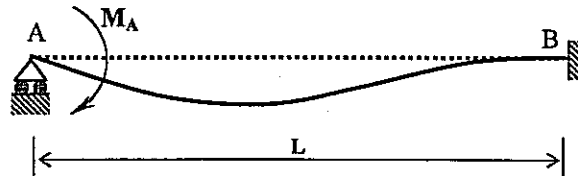

Fig. 3(a)

[05 marks]

- b.) Analyse the beam shown in Fig. 3(b), using Moment Distribution Method and sketch the Bending Moment diagram ( $EI = \text{Constant}$ ).

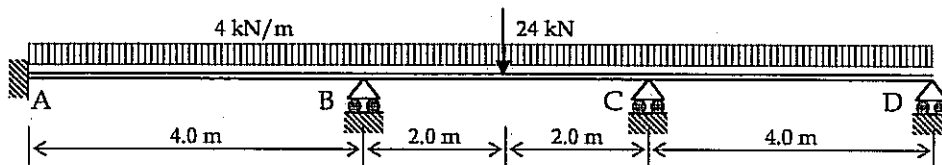

Fig. 3(b)

[15 marks]

Q4.

- a.) Using Castigliano's Theorem determine the vertical deflection at the centre of the simply supported beam in Fig. 4(a), ( $EI = \text{constant}$ ).

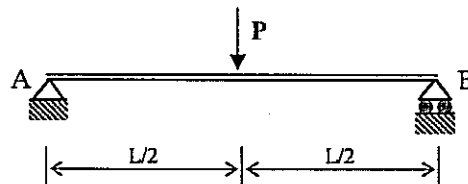

Fig. 4(a)

[10 marks]

- b.) Analyse the propped cantilever beam shown in Fig. 4(b), using Castigliano's Theorem and determine the support reactions. ( $EI = \text{Constant}$ ).

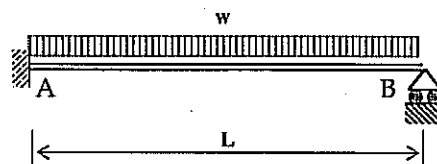

Fig. 4(b)

[10 marks]



## Section B - - - Structural Design

All designs are to be done according to the recommendations of the Standard BS 8110. (Handout provided)  
For questions Q5 Q6 & Q7 use the data and parameters pertaining to the following structure.

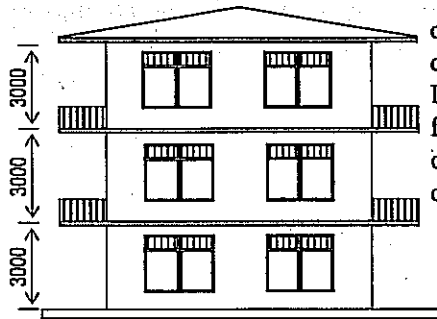

Side Elevation

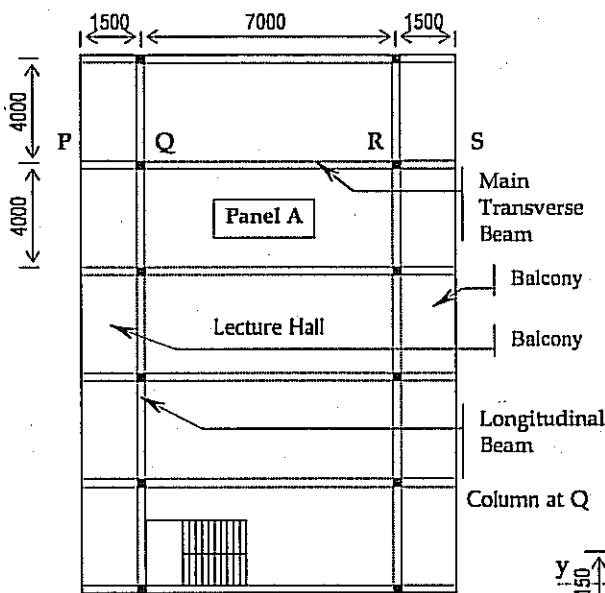

Plan of an upper floor slab

### General Notes:

- \* Dotted lines indicate beams cast integral with slabs.
- \* Grids are spaced equally.
- \* Marked intersection points of beams are supported on 200 x 150 mm RC columns
- \* Transverse beams (ex. PQRS) are of 500 x 300 mm & longitudinal beams are 300 x 200 mm cross-section
- \* Transverse beams do not carry any walls on top
- \* Slabs are to be 125 mm thick
- \* Roof is entirely supported by the 12 columns.
- \* Block work peripheral walls are 100 mm thick
- \* All dimensions are in 'mm'.

### Material & Load Specifications:

Concrete grade	- C35
Grade of Steel $f_y$ HYS	- 460 N/mm <sup>2</sup>
MS	- 250 N/mm <sup>2</sup>
Unit weight of concrete	- 24 kN/m <sup>3</sup>
Unit weight of block Masonry	- 18 kN/m <sup>3</sup>
Dead load by roof (incl. ceiling)	- 1.0 kN/m <sup>2</sup>
Weight of finishes on slab	- 1.0 kN/m <sup>2</sup>
Imposed load on slab	- 3.0 kN/m <sup>2</sup>
Nominal cover for reinforcement	- 20 mm
* Use only necessary values *	

- Q5. Using the given data, design the 'Panel A' of the upper floor slab, assuming all loads to be uniformly distributed. Follow the steps below for the design.
- i.) Decide on a nominal cover for reinforcement against SLS Durability. Calculate the Characteristic (dead load & imposed load due to normal loading) and the Design load on the panel as area loads. [02 marks]
  - ii.) Identify the spanning condition, end conditions of the slab and evaluate appropriate mid span and over the support moments for the ULS of flexure. You may use the factors from table in the handout. [05 marks]
  - iii.) Design reinforcement against ULS of flexure to resist bending at mid spans and over supports for the slab panel. (Assume 10 mm HYS for main reinforcement). [05 marks]
  - iv.) Check against the SLS of deflection for the slab panel and if necessary, propose suitable modifications. [04 marks]
  - v.) Sketch the reinforcement on a plan and one cross section of the slab panel using the Standard Method of Detailing ( not necessary to indicate curtailment lengths). [04 marks]



- Q6. Using data pertaining to the structure given above, design the beam PQRS (there are no walls on the beam), along following steps (assume that the effective beam section is rectangular and all loads transferred to the beam are uniformly distributed.);
- i.) Evaluate the characteristic dead and imposed loads transferred on to the beam and the maximum design load as linear loads (You may assume that balconies carry the same imposed load as the lecture hall). [02 marks]
  - ii.) Calculate the design bending moments and shear forces at mid span & support sections of the beam and sketch the Bending moment and Shear force diagrams. [05 marks]
  - iii.) Design the reinforcement against ULS of flexure at the critical sections (supports & mid span) of the double cantilever beam. (You may assume 20 mm dia. HYS steel main tensile reinforcement & 6 mm dia. MS shear stirrups.) [04 marks]
  - iv.) Check for ULS of shear at critical sections of the beam and provide shear reinforcement if necessary. (You may assume two or four legged 6 mm MS shear stirrups.) [05 marks]
  - v.) Check against SLS of deflection of the beam based on conditions at the mid span. Only propose modifications if this check fails. [04 marks]
- Q7. Using data pertaining to the structure given above, design the Column segment from 1<sup>st</sup> floor to 2<sup>nd</sup> floor at location Q, along the following steps.
- i.) Determine the type of the column segment (braced/unbraced), about its two principle axes of bending and state reasons for your conclusions. [02 marks]
  - ii.) Evaluate the effective heights, and slenderness ratios of the column segment and determine the slenderness condition (slender/short), about both principle axes. Clearly state reasons for your answers. [04 marks]
  - iii.) Evaluate the characteristic loads and calculate design axial load and design bending moments (if any) acting on the column segment. You should pay due consideration to the moments created by eccentricity of loading and possibility of slenderness buckling in evaluating these values. [06 marks]
  - iv.) Design the column main reinforcement against ULSs of compression & flexure and the tie requirement against SLS of cracking, assuming a symmetrical arrangement of reinforcement. (Assume 16 mm HYS bars for main steel & 6 mm MS bars for ties). [04 marks]
  - v.) Produce a detailed reinforcement sketch with column in elevation and required cross sections. You should adopt the standard method of detailing. [04 marks]

