

Date: 26th of March 2006

Time – 9.30 – 12.30 hrs

Answer Section A and, any two (2) questions from Section B and two (2) from section: C.

Section A carries 24% and Section B and C carry 38% each.

Attach Section A to answer script for Sections B&C after writing answers in the spaces provided.

SECTION B

Answer two questions only from section B

Answers should be written clearly and neatly, stating any necessary assumptions and showing necessary derivations.

Q1 a). A pin-jointed truss formed with 2m length members is hinged to a support at U1, on a roller support at U5 and loaded as shown in the figure below. Determine the forces in all the members of the frame by the 'method of joints'.

(14 Marks)

b). Determine the forces in members U2U3, U2L2, L1L2 of the truss by the 'method of section'.

(5 Marks)

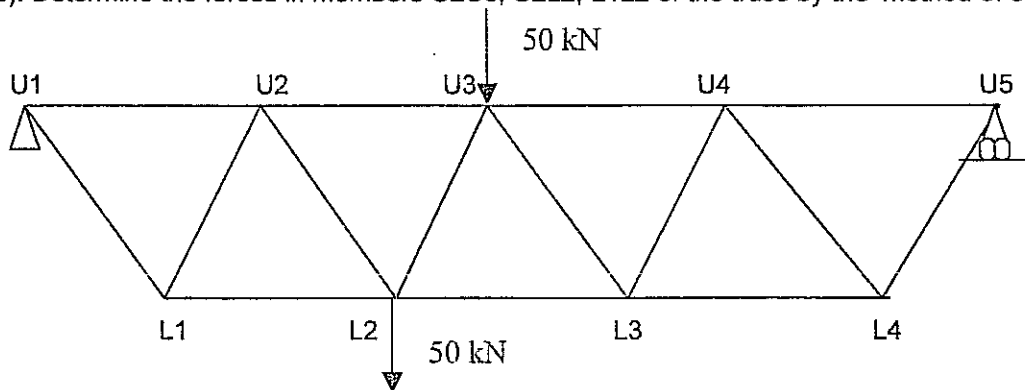

2 A pin-jointed frame is hinged to the support at U1 and on a roller support at L3 as shown in the figure below. Take EA as constant for all members.

Calculate the following and indicate the direction of the movement caused by the given load:

- i). the vertical deflection of the point U2 (7 Marks)
- ii). the vertical deflection of the point L1 (6 Marks)
- iii). the horizontal deflection of the point L1 (6 marks)

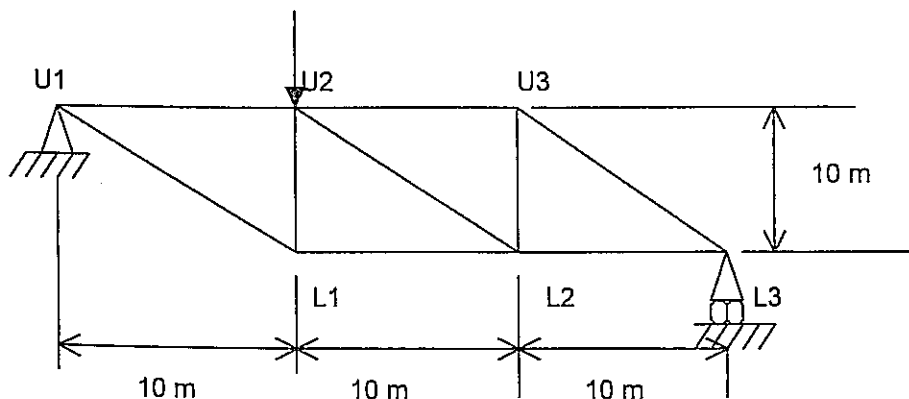

3. a) Draw a influence lines of a following actions of the given beam below.

- i.) Bending moment at mid span of AB
- ii.) Bending moment at B
- iii.) Shear force at A

(8 Marks)

b). Find out the maximum effect of bending moment at mid span of AB and shear force at A for

- i). Moving two concentrated loads each of 5 kN and which are apart of distance 4 m.
- ii). Moving uniformly distributed load of 5 kN/m only 2 m long.

(11 marks)

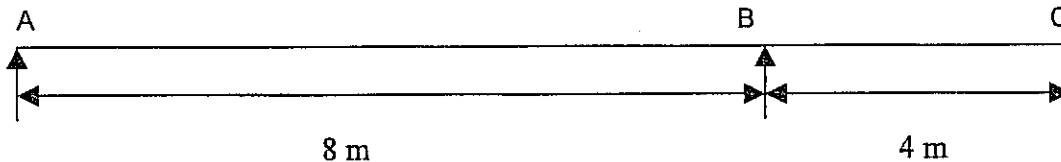

SECTION C

Data sheets are available and should be **returned** please, before you leave the examination hall

4. a). A truss has double angle members forming the bottom chords. A bottom chord of the truss is subjected to 50 kN of maximum tensile force and 4 kNm of maximum bending moment. Check the suitability of the 70x70x10 double angle members for above mentioned bottom chord. The double angle members are bolted with 16 mm diameter bolts to both sides of the gusset plate. Take allowable stress in axial tension as 170 N/mm² and allowable tensile bending stress as 170 N/mm².

(12 Marks)

b). Check if two 16 mm diameter bolts are sufficient to connect the above tensile member to a 12 mm thick gusset plate. The allowable strengths are:

- the allowable stress in bolts in clearance holes, in shear = 80 N/mm²
- the allowable stress in bolts in clearance holes, in bearing = 250 N/mm²
- the allowable bearing stresses on connected parts = 250 N/mm²
- the edge distance of 18 mm diameter holes = 28 mm

(7 Marks)

the properties of a 70x70x10 equal angle as follows

Area of Section = 13.1 cm², distance to centre of gravity c = 2.1 cm,

Second moment of area

relative to xx-axis and y-y axis = 58.0 cm⁴, relative u-u axis = 91.6 cm⁴,

relative v-v axis = 21.4 cm⁴

Radius of gyration

relative to x-x axis and y-y axis = 2.1 cm

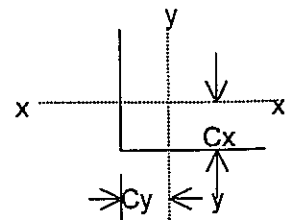

5 a). A double angle member formed with legs of 75 x 75 x 10 connected back to back to both sides of an 8 mm thick gusset plate. Find out r_{xx} and r_{yy} of given double angle.

(8 marks)

b). Check that the above-mentioned double angle is safe from buckling assuming effective length of the members for all axes as 3.5 m.

(8 Marks)

c). Find out the compression capacity of the above double angles.

(3 Marks)

6. a). A double angle member 70x70x10 of steel grade 43, subjected to a tensile load of 180 kN has to be spliced as shown in the figure. Check whether the joint is satisfactory.

...(14 Marks)

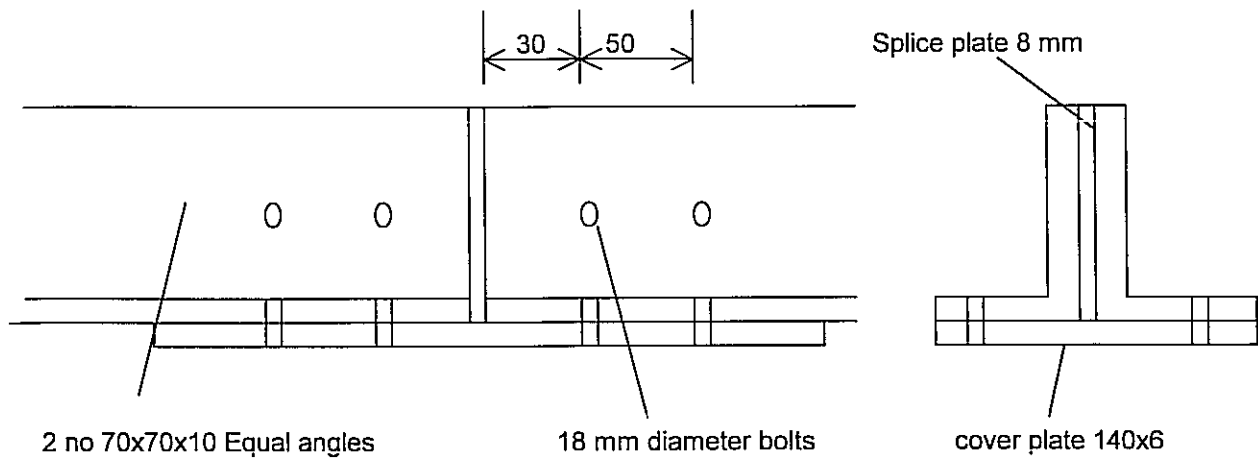

c). State the differences between butt weld and fillet weld used in connections of steel sections with suitable sketches (5 Marks)