



THE OPEN UNIVERSITY OF SRI LANKA

B. Sc. Degree Programme — Level 4

Final Examination — 2011/2012

CMU 2220 — Concepts in chemistry

(3 hours)

29th November 2012 (Thursday)

9.30 am — 12.30 pm

- There are six (06) questions and eight (08) pages (including the first page) in the paper.
- Answer ALL 06 (six) questions.
- The use of a non-programmable calculator is permitted
- Cellular phones are not allowed.

Gas constant (R)	=	8.314 J K ⁻¹ mol ⁻¹
Avogadro constant (N _A)	=	6.023 × 10 ²³ mol ⁻¹
Faraday constant (F)	=	96,500 C mol ⁻¹
Planck constant (h)	=	6.63 × 10 ⁻³⁴ J s
Velocity of light (c)	=	3.0 × 10 ⁸ m s ⁻¹
Standard atmospheric pressure	=	10 ⁵ Pa (N m ⁻²)
Protonic charge (e)	=	1.602177 × 10 ⁻¹⁹ C
π	=	3.14159
Log _e (X)	=	2.303 Log ₁₀ (X)

Some equations used in chemistry are given below using standard notation.

$$\log(\gamma_{\pm}) = -A Z_+ |Z_-| \sqrt{I}, \quad E_J = B J(J+1), \quad N_j = N_i \left(\frac{g_j}{g_i} \right) \exp\left(-\frac{E_j - E_i}{kT} \right), \quad \bar{v}_J = 2\bar{B}(J+1)$$

$$\eta = \frac{I}{h\nu}, \quad \bar{B} = \frac{h}{8\pi^2 \mu R^2 c}, \quad \lambda_{\pm} = u_B |Z_{\pm}| F, \quad v_B = u_B E, \quad \kappa_B = u_B c_B |Z_B| F, \quad j = \kappa E$$

$$u = x a \kappa / Q$$

1. (a) Write down Beer-Lambert law in absorption spectroscopy and identify all the parameters in it.

(10 marks)

- (b) A fabric dyeing plant has two adjacent tanks partially filled with dilute aqueous solutions of two dyes A and B as indicated in the following figure.

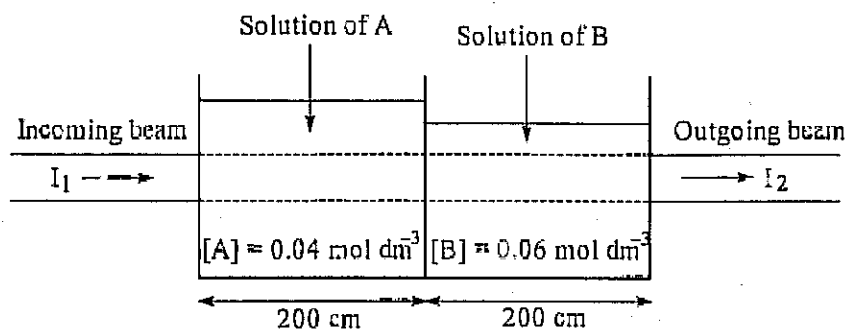

The width of each tank is 200 cm. The concentrations of A and B, in units of mol dm^{-3} , are 0.04 and 0.06 respectively. A student passed a narrow, parallel beam of microwave radiation of high frequency through the two tanks as indicated in the figure. The intensity, I_1 , of the incoming beam was $2.5 \times 10^{-5} \text{ W m}^{-2}$. The molar extinction coefficients of A and B, in units of $\text{dm}^3 \text{ mol}^{-1} \text{ cm}^{-1}$, are 0.06 and 0.03 respectively. [Assume that the walls of the tanks and water do not absorb microwaves used by the student, and that there is no loss of radiation (due to reflection and scattering) at the walls of the tanks.]

- (i) Derive a relationship between the intensity, I_1 , of incoming beam, intensity, I_2 , of the outgoing beam, concentrations $[A]$ and $[B]$, and the width of each tank, l .
 (ii) Calculate the intensity I_2 .

(60 marks)

- (c) Answer either Part A or Part B (but NOT both).

Part A

Consider a molecule having only four energy levels which are equally spaced. Each energy level is identified by two quantum numbers (λ, δ) as indicated in the figure to the right. The selection rules in spectroscopy of the molecule are $\Delta\lambda = 0, \pm 1$ and $\Delta\delta = 0, \pm 1$. Giving reasons, deduce the maximum number of lines that may be observed in the absorption spectrum of a sample of these molecules.

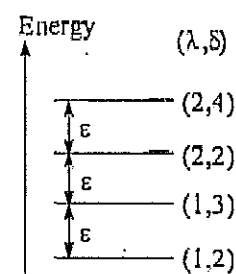

(30 marks)

[Question 1 is continued in the next page]

Part B

The bond angle in a molecule, AB_2 , is 120° as shown in the figure. Atom B is more electronegative than atom A. The dipole moment of each of the AB bonds is 0.54 D.

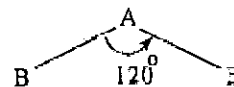

- (i) Calculate the dipole moment of AB_2 molecule.
- (ii) Copy the above diagram of the structure of AB_2 on to your answer script and indicate the direction of the dipole moment, using an arrow as is usually done, on it. Indicate the angle between an AB bond and the arrow of dipole moment on this diagram.

(30 marks)

2. (a) The first 8 lines in the microwave spectrum of a diatomic molecule, AB, is schematically represented in the following diagram.

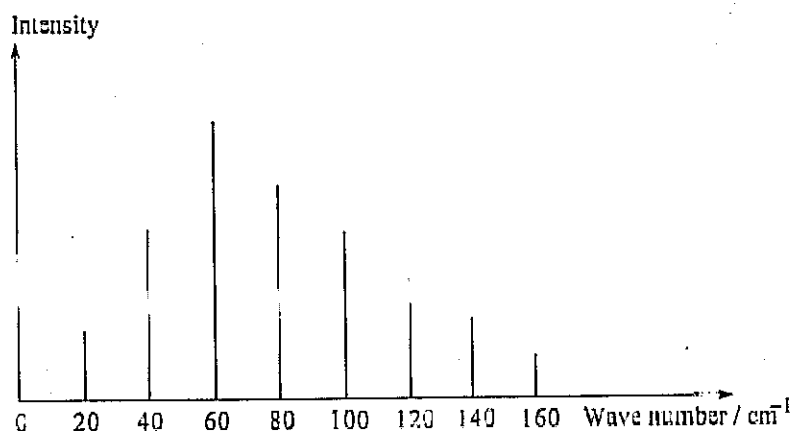

- (i) Starting with an equation that gives the position of lines in the microwave spectrum of a diatomic molecule, deduce the relationship between the rotational constant and the spacing between two adjacent lines in the microwave spectrum.
- (ii) Deduce the value of the rotational constant of AB using the above figure.
- (iii) Calculate the bond length of AB
[Relative atomic masses of A and B are 1.0 and 35.0 respectively]

(50 marks)

- (b) Explain clearly the terms,

- (i) Chemical potential
- (ii) Partial molar volume

(10 marks)

- (c) Starting from the Clapeyron equation, derive the Clausius – Clapeyron equation, indicating the conditions under which it may be applied.

(15 marks)

[Question 2 is continued in the next page]

Part B

The bond angle in a molecule, AB_2 , is 120° as shown in the figure. Atom B is more electronegative than atom A. The dipole moment of each of the AB bonds is 0.54 D.

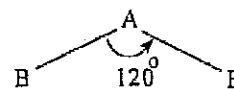

- (i) Calculate the dipole moment of AB_2 molecule.
- (ii) Copy the above diagram of the structure of AB_2 on to your answer script and indicate the direction of the dipole moment, using an arrow as is usually done, on it. Indicate the angle between an AB bond and the arrow of dipole moment on this diagram.

(30 marks)

2. (a) The first 8 lines in the microwave spectrum of a diatomic molecule, AB, is schematically represented in the following diagram.

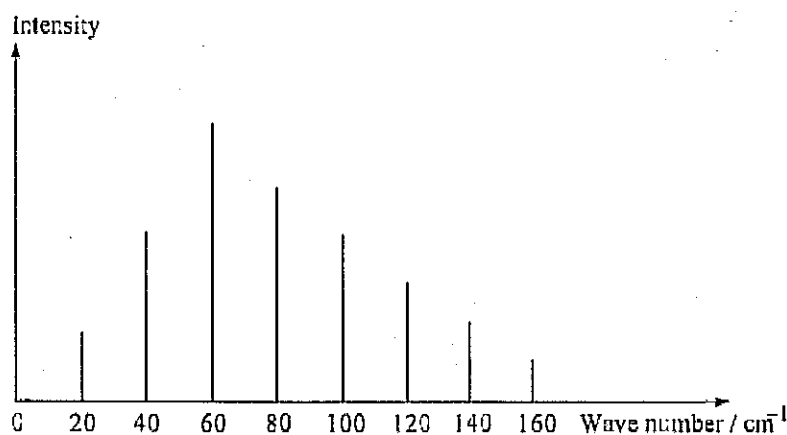

- (i) Starting with an equation that gives the position of lines in the microwave spectrum of a diatomic molecule, deduce the relationship between the rotational constant and the spacing between two adjacent lines in the microwave spectrum.
- (ii) Deduce the value of the rotational constant of AB using the above figure.
- (iii) Calculate the bond length of AB
[Relative atomic masses of A and B are 1.0 and 35.0 respectively]

(50 marks)

- (b) Explain clearly the terms,

- (i) Chemical potential
- (ii) Partial molar volume

(10 marks)

- (c) Starting from the Clapeyron equation, derive the Clausius – Clapeyron equation, indicating the conditions under which it may be applied.

(15 marks)

[Question 2 is continued in the next page]

- (c) At 298 K, the standard enthalpy of formation (ΔH_f°) of $\text{NH}_3(\text{g})$ is $-46.11 \text{ kJ mol}^{-1}$. Assuming that the molar heat capacities can be represented by expressions of the form $C_{p,m} = A + BT$, with the coefficients A and B given below, calculate ΔH_f° at 1000 K.

	$\text{N}_2(\text{g})$	$\text{H}_2(\text{g})$	$\text{NH}_3(\text{g})$
$A/\text{J K}^{-1} \text{ mol}^{-1}$	28.58	27.28	29.75
$10^3 \times B/\text{J K}^{-2} \text{ mol}^{-1}$	3.77	3.26	25.1

(25 marks)

3. (a) (i) A measured volume, $y \text{ cm}^3$, of a liquid A [relative molar mass = 100 and density = 800 kg m^{-3}] is mixed with 25.00 g of a liquid B [relative molar mass = 125]. If the mole fraction of A in the solution is 0.4, determine y .
- (ii) If 10.0 g of a third compound, C (fully miscible with the other two) of relative molar mass 40.0 is added to the above mixture, determine the mole fraction of A in the new mixture.

(20 marks)

- (b) The vapour pressures (P°) of pure Benzene (B) and pure Toluene (T) have the following values in the temperature range between their boiling points and at a pressure of one (1) bar. B and T is said to form an ideal binary mixture at all compositions.

$T/^\circ\text{C}$ (Boiling Point)	80	90	95	100	105	110
$P^\circ(\text{benzene})/\text{bar}$	1.00	1.30	1.50	1.80	P_B°	—
$P^\circ(\text{toluene})/\text{bar}$	—	0.50	0.60	0.75	P_T°	1.00

- (i) Determine the corresponding set of vapour pressures of pure compounds [P_B° , P_T° as shown in the above table] at 105°C , given that, in a mixture of benzene and toluene, $X_B = 0.1$ and $Y_B = 0.2$ when the boiling point of the mixture is 105°C and the total pressure is 1 bar. (X_B is the mole fraction of B in the liquid phase Y_B is the mole fraction of B in the vapour phase).
- (ii) Calculate the compositions of liquid phase in terms of the mole fraction of B at each of the above temperatures at the total pressure of 1 bar and hence, generate the relevant table of values required to plot the "boiling point ($T/^\circ\text{C}$) versus composition, (X_B)" phase diagram.

Identify/name all relevant mathematical expressions used in the above calculations.

[Hint: The total pressure is always equal to 1 bar.]

(40 marks)

[Question 3 is continued in the next page]

- (c) Consider two immiscible liquids, A and B, in equilibrium with vapour at a specified temperature. The equation given below relates the relative weight of the two liquids

present in the vapour/condensate, $\left[\frac{W_A}{W_B} \right]$.

$$\frac{W_A}{W_B} = \frac{P_A^0 M_A}{P_B^0 M_B}$$

A mixture of aniline and water (two immiscible liquids) boils at 98°C. The vapour pressure of aniline and water at this temperature are 42 mm Hg and 718 mm Hg respectively. Calculate the amount of aniline that can be collected for each 75 g of water by steam distillation [Relative atomic masses: O=16; C=12; H=1]

(15 marks)

- (d) Answer either Part A or Part B (but NOT both).

Part A

Two metals A and B (melting point of A = 1200°C; melting point of B = 900°C) are said to form a simple eutectic system at elevated temperatures. The eutectic composition corresponds to a melt containing 1.5 moles of A and 3.0 moles of B. The cooling curve corresponding to the eutectic composition shows a “halt” at 650°C.

Sketch a fully labelled phase diagram for the above system.

(25 marks)

Part B

Sketch the cooling curve for the melt of a pure solid.

Explain the statement “The shape of the cooling curve corresponding to a pure solid and that of a eutectic composition of two components are similar” based on phase changes occurring during the cooling process and the application of phase rule.

(25 marks)

4. (a) (i) Starting from the definition $G = H - TS$, derive the fundamental equation $dG = V dP - S dT$, for a reversible process in a closed system.
- (ii) Using the expression derived in (i), write down the pressure and temperature coefficients of Gibbs free energy and Maxwell relationship.
- (iii) Write down the integrated form of the Gibbs-Helmholtz equation.
- (iv) Show that for the i^{th} component in a mixture (in standard notation),

$$\left[\frac{\partial}{\partial T} \left(\frac{\mu_i}{T} \right) \right]_{P,n} = -\frac{\bar{H}_i}{T^2}$$

(40 marks)

[Question 4 is continued in the next page]

- (b) (i) Consider the following reaction,



Write down van't Hoff reaction isotherm and identify all the terms in it.

- (ii) The equilibrium constant at 298K for the synthesis of ammonia is $812 \text{ mol}^{-2} \text{ dm}^6$ and the standard enthalpy change ΔH^\ominus is $-26.11 \text{ kJ mol}^{-1}$.

Calculate the equilibrium constant of this reaction at 398K. Assume that ΔH^\ominus is constant over this range.

(40 marks)

- (c) Standard enthalpy of formation of monoclinic sulfur from rhombic sulfur at the standard transition point of 368.5 K is -402 J mol^{-1} . Justify the validity of Third law of Thermodynamics by making use of the data given.

(20 marks)

5. (a) The setup used by a student in hydrolysing an aqueous solution of sulphuric acid using two graphite rods, A and B, and a battery is shown in the figure. The electric current drawn from the battery is denoted by I . It was observed that the rate of flow of $\text{H}^+(\text{aq})$, $\text{HSO}_4^-(\text{aq})$ and $\text{SO}_4^{2-}(\text{aq})$ through a cross section of the solution (see the figure), in units of mol s^{-1} , were 6.22×10^{-5} , 1.05×10^{-5} and 1.55×10^{-5} , respectively.

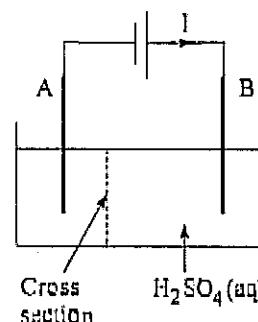

- (i) Calculate the current, I , drawn from the battery.
State the assumptions, if any, you make in this calculation.
- (ii) Calculate the transport numbers of $\text{H}^+(\text{aq})$, $\text{HSO}_4^-(\text{aq})$ and $\text{SO}_4^{2-}(\text{aq})$ in the solution.

(40 marks)

- (b) Answer either Part A or Part B (but NOT both).

Part A

- (i) Define the following terms.
- (α) Drift speed of an ionic species.
- (β) Ionic mobility.
- (ii) A student prepared a solution, X, by dissolving the strong electrolytes, NaNO_3 and $\text{Mg}(\text{NO}_3)_2$ in water. The concentrations, in units of mol dm^{-3} , of NaNO_3 and $\text{Mg}(\text{NO}_3)_2$ in this solution were 0.75 and 0.55, respectively. It was known that the ionic mobilities of $\text{Na}^+(\text{aq})$, $\text{Mg}^{2+}(\text{aq})$ and $\text{NO}_3^-(\text{aq})$, in units of $\text{m}^2 \text{ V}^{-1} \text{ s}^{-1}$, in this solution were, 5.19×10^{-8} , 5.50×10^{-8} and 7.40×10^{-8} , respectively.

[Question 5 is continued in the next page]

- (α) Disregarding the conductivity due to $\text{H}^+(\text{aq})$ and $\text{OH}^-(\text{aq})$, write down a relationship between the conductivity of solution X and the conductivities of the ions in it and identify all the terms in it.
- (β) Calculate the conductivity of solution X.
- (γ) Briefly describe what is meant by the phrases, “conductivity due to NaNO_3 ” and “conductivity due to $\text{Mg}(\text{NO}_3)_2$ ” in solution X.
- (δ) Calculate the conductivities due to NaNO_3 and $\text{Mg}(\text{NO}_3)_2$ in solution X.
- (θ) Calculate the molar conductivities of NaNO_3 and $\text{Mg}(\text{NO}_3)_2$ in solution X.

(60 marks)

Part B

- (i) (α) Define the transport number, t_B , of an ionic species, B, in an electrolyte solution.

(β) Show that
$$\sum_{\substack{B = \text{all} \\ \text{ions}}} t_B = 1$$

(15 marks)

- (ii) The apparatus used by a student in measuring the ionic mobility of the negative ion in a solution of a binary salt, using the moving boundary method, is schematically represented in the figure. A and B are the two solutions used. Note that the apparatus is kept vertically so that solution B lies above solution A.

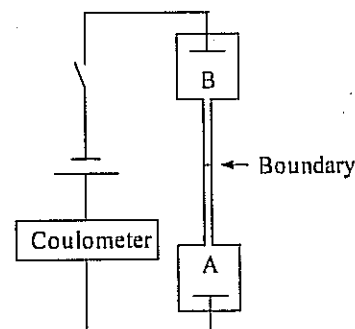

- (α) Giving reasons, state the direction of movement of the boundary during the experiment.
- (β) Giving reasons, identify the solution which had the ion whose ionic mobility was measured.
- (γ) Giving reasons, state the solution (out of A and B) which has the higher density.

(25 marks)

- (iii) The moving boundary method was applied to a $0.0200 \text{ mol dm}^{-3}$ aqueous NaCl solution at 25°C using aqueous CdCl_2 as the following solution. For a current held constant at 1.600 mA , it was found that the boundary moved 0.100 m in 3453 s , in a tube of average cross sectional area $1.115 \times 10^{-5} \text{ m}^2$. The conductivity of the NaCl solution, at 25°C and 1 atm , is 0.2313 S m^{-1} . Calculate the ionic mobility of Na^+ at 25°C , in this solution.

(20 marks)

6. (a) Consider a reaction of the form $A + 3B \rightarrow AB_3$.

- (i) Write down the general expression for $-\frac{d[B]}{dt}$, the rate of the reaction.
- (ii) Write down the symbolic expression for the overall order of this reaction based on your answer in (i) above
- (iii) Assuming it to be a zero order reaction with respect to A and second order with respect to B, derive the integrated form of the rate equation from the expression written above.
- (iv) Define half life $t_{1/2}$ and hence, write down the expression for $t_{1/2}$ based on the expression derived in (iii) above.
[Consider the initial concentration of B to be b_0 , concentration at any time, t as b and the concentration of the amount reacted after time, t , as x .]

(40 marks)

(b) The second order reaction, $OH^- + C_2H_5OH \rightarrow C_2H_5O^- + H_2O$ under pseudo first order conditions (with excess NaOH, the concentration of NaOH being equal to 0.2M) gave a value of $4.4 \times 10^5 \text{ min}^{-1}$ for the pseudo first order rate constant.

Calculate the rate constant for the second order reaction.

(10 marks)

(c) Consider the following reversible reaction $A \rightleftharpoons B$ which is second order in the forward direction and first order in the backward direction. The rate constants for the forward and the backward reactions are k_1 and k_2 , respectively.

Write down the rate equation for $-\frac{d[A]}{dt}$, the rate of disappearance of A and, determine the value of the ratio $\frac{k_2}{k_1}$ (at equilibrium) in terms of the concentrations of A and B.

(20 marks)

(d) The decomposition of a gaseous molecule, A, is said to be a two-step reaction as shown below.

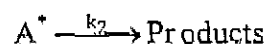
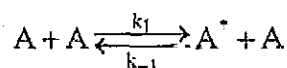

(i) What do you understand by the term "steady state assumption" as applied in kinetic studies?

(ii) Show that $-\frac{d[A]}{dt} = \frac{k_1[A]^2}{1 + \frac{k_{-1}}{k_2}[A]}$ under steady state conditions.

(30 marks)