

The Open University of Sri Lanka
B.Sc. Degree Programme- Level 05
Final Examination 2010/2011
PHU 3150/PHE 5150- Data Acquisition and Signal Processing



Duration: Two (2) Hours

Date: 29.12.2011

Time: 1.30 p.m. – 3.30 p.m.

ANSWER FOUR QUESTIONS ONLY.

1. (a) Describe the difference between input and output transducers.
- (b) Write down one input and one output transducer to measure the following physical variables.
 - (i) Temperature
 - (ii) Displacement
 - (iii) Light
- (c) By replacing R_T with a suitable input transducer the output voltage (V_{out}) of the following circuit can be changed into an electrical signal following the variation of the physical variable under measurement.

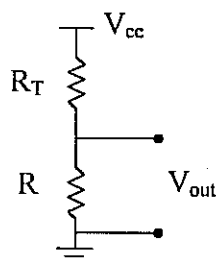

Figure 1

- (i) Derive an expression for the output voltage of the circuit in figure 1.
- (ii) Hence calculate the output voltage of this circuit under light and dark when R_T is replaced with a light dependant resistor which has a resistance of $10\text{ k}\Omega$ in light and $200\text{ k}\Omega$ in dark. Take the fixed resistor $R = 10\text{ k}\Omega$ and $V_{cc} = 5\text{ V}$ in your calculations.
- (d) How do you modify this circuit to control a light source that operates with 230 V AC , when additional components such as resistor, transistor, diode and a relay are provided?

2. (a) What are the ideal characteristics of an operational amplifier? Write down the two golden rules derived from the ideal characteristics.
- (b) Figure 2 shows a circuit diagram of a non inverting amplifier circuit. Derive an expression for the output voltage of the circuit. Hence show that the voltage gain of this circuit is $\left(1 + \frac{R_2}{R_1}\right)$.

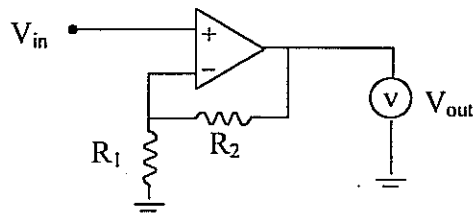

Figure 2

- (c) If the full scale of the voltmeter connected at the output of this circuit is 10 V and $R_1 = 1 \text{ k}\Omega$, how do you construct a multi-range voltmeter with the following ranges?
- 0 – 1.0 V
 - 0 – 5.0 V
- (d) Why do you think this voltmeter constructed with an operational amplifier is more accurate than an analogue voltmeter?
- 3 (a) Briefly explain, why does the spectrum analysis be a powerful tool in signal processing.
- (b) Draw the waveform $f(t)$ given bellow and Fourier transform it to get the sinusoidal wave forms.

$$f(t) = \begin{cases} 0 & \text{if } 0 < t < T/2 \\ 1 & \text{if } T/2 < t < T \end{cases}$$

- (c) Plot the power spectrum of this signal.
- (d) After transforming this signal into sinusoidal wave forms suppose you pass them through a filter circuit to cut off the frequencies greater than $6f_0$. How do you construct a RC filter circuit for this purpose? If the resistor in this circuit is 1 k Ω , calculate a suitable value for the capacitor.

4. (a) Write down four methods of converting analogue signals into digital signals.
- (b) Figure 3 shows an analogue to digital converter (ADC) based on integration method. Explain briefly how an analogue voltage converts to a binary number with this circuit.

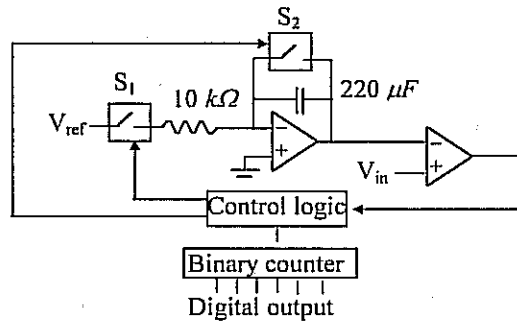

Figure 3

- (c) Show that the integrated voltage, $V_{int} = \frac{V_{ref} t}{RC}$ for the integrator of this circuit in a period of time t .
- (d) Hence calculate the time taken by the above ADC to convert an analogue voltage of 3.7 mV when $V_{ref} = 5$ V.
5. (a) Name the register set in a typical microprocessor. Explain how do these registers help in the general operation sequence (fetch execute cycle) to perform a task in a microprocessor?
- (b) What is meant by the terms mnemonics, assembly language and machine language in computer programming.
- (c) Write a programme in assembly language to subtract 2 from 3.
- (d) Convert assembly language programme written in (c) into machine language and draw the memory allocation of the programme when stored in an external memory beginning from the address 10_{16} . Use the following op codes when you convert the assembly language programme to machine codes.

01 - MOV A, n	02 - MOV B, n
03 - DEC A	04 - DEC B
06 - CMP B, n	07 - ADD A, B
09 - JG m	0B - NOP

6. (a) In computer vocabulary what is meant by Bits and Bytes? Why does the hexadecimal number system become important in programming even though the computer understand only the binary number system?
- (b) Calculate the size of total accessible memory of a Motorola MC6809 processor in bytes, which has 16 bits address bus and 8 bits data bus. Write down the lowest and the highest accessible address of this processor in hexadecimal.
- (c) Draw the memory map of the above processor when 2716 EPROM (2048 x 8 bit) and 6116 RAM (2048 x 8 bit) are connected. Choose the address range of the 2716 EPROM ending at the highest accessible address and address range of the 6116 RAM starting from the lowest accessible address of the processor.
- (d) Design address decoding circuits for 2716 EPROM and 616 RAM using suitable gates.

=====END=====